

Supporting Information

Fully Continuous Flow Synthesis of 5-(Aminomethyl)-2-methylpyrimidin-4-amine: A Key Intermediate of Vitamin B₁

Meifen Jiang,^{*†} Minjie Liu,[‡] Huasha Huang,[‡] Fener Chen^{*†‡}

S1. Continuous flow synthesis of 2-(dimethylaminomethylidene)propanedinitrile (4) in a Protrix microchannel reactor

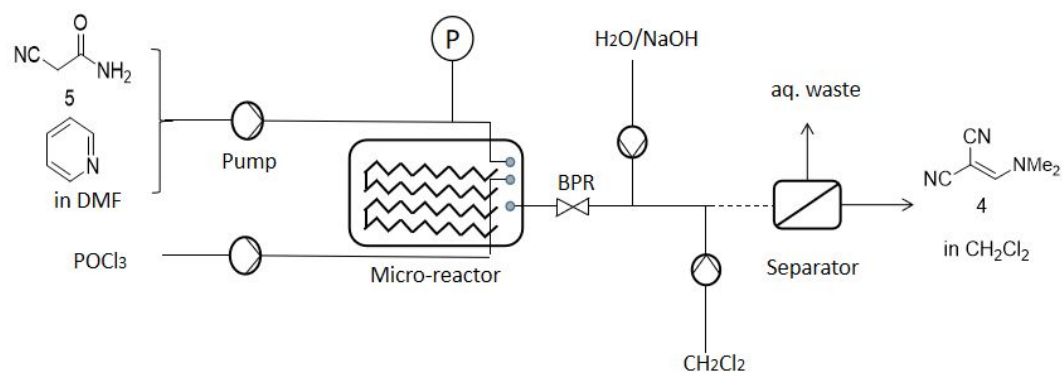

Figure S1. Continuous flow synthesis of compound 4 using a Protrix microchannel reactor

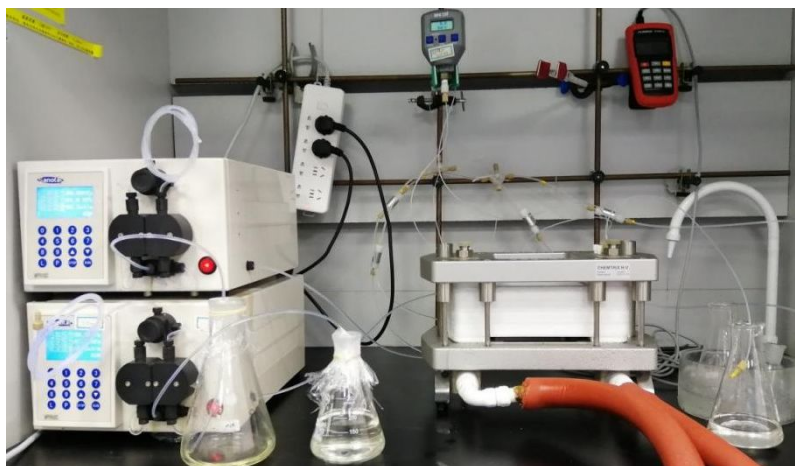

Figure S2. Continuous flow synthesis set- up for compound 4 in a Protrix microchannel reactor

Table S1. Effects of temperature and reaction time on reaction conversion

Entry	Volume (ml)	Residence time (min)	Temperature (°C)	Conversion (%)	Yield (%)
1	12.6	30	-10	84	/
2	12.6	30	-5	86	/
5	12.6	30	0	89	/
6	12.6	30	5	88	/
7	12.6	30	10	90	/
8	12.6	30	15	85	/
9	12.6	30	20	88	/
10	12.6	30	25	92	78
11	12.6	20	10	78	/
12	12.6	20	20	85	72
13	12.6	60	10	91	62

S2. Clogging in the flow synthesis of 4-amino-2-methylpyrimidine-5-carbonitrile (3)

in a Coflore ACR



Figure S3. Clogging in ACR

S3. Products from 3 single step continuous flow synthesis

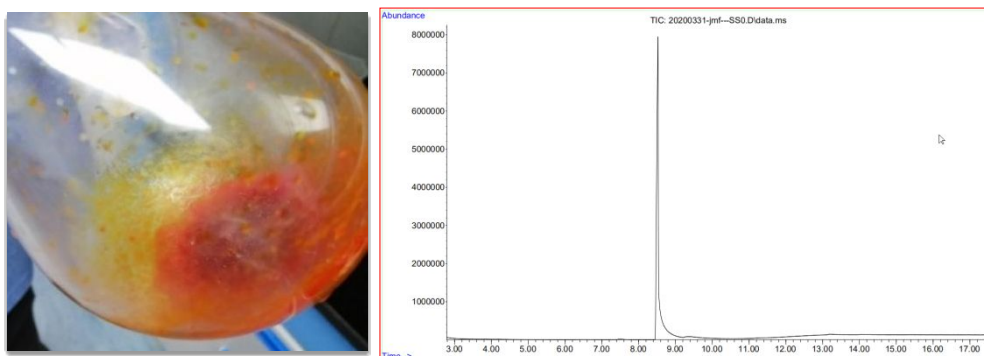

Figure S4. 2-(dimethylaminomethylidene)propanedinitrile (4) generated by continuous flow synthesis in the microchannel coil reactor

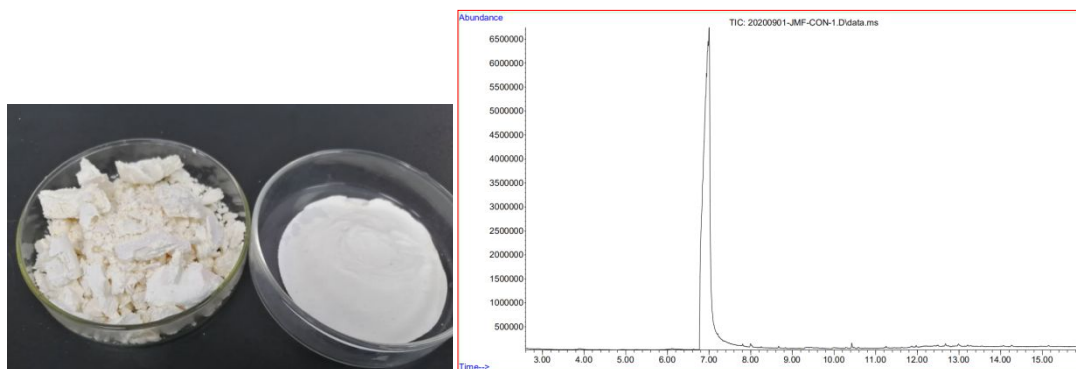

Figure S5. 4-amino-2-methylpyrimidine-5-carbonitrile (**3**) generated by continuous flow synthesis in the ACR

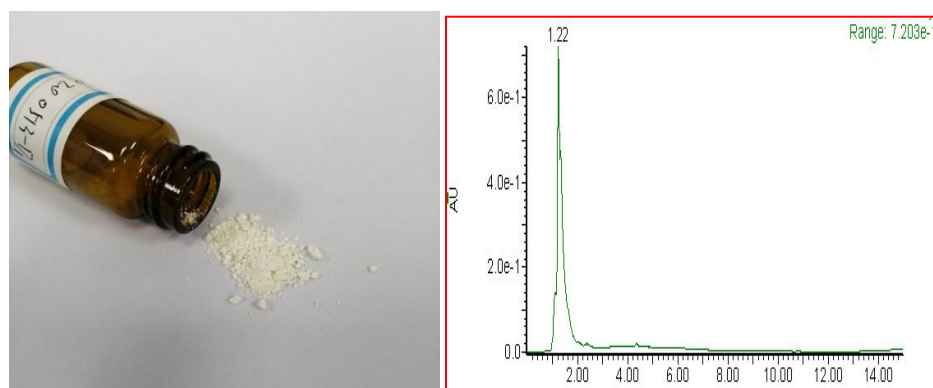

Figure S6. 5-(Aminomethyl)-2-methylpyrimidin-4-amine(**2**) generated by continuous flow synthesis in the fixed-bed reactor

S4. Continuous extraction using a CINC Model-continuous Inline extractor

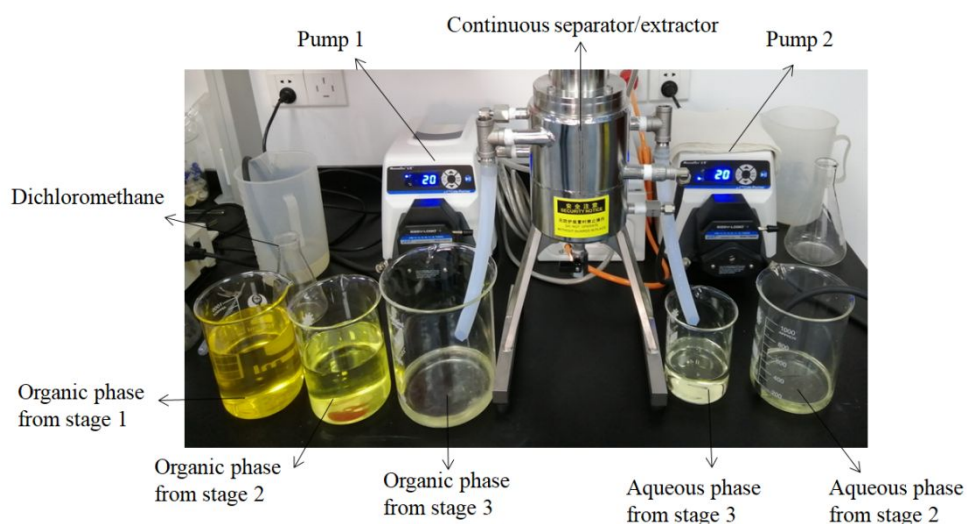

Figure S7. Continuous extraction using a continuous inline extractor by CINC Deutschland GMBH and Co.